

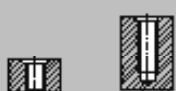
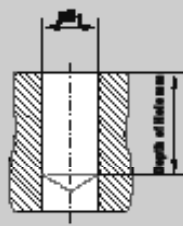
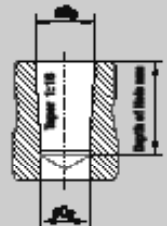

DESCRIZIONE: **Maschi a mano**

CODICE: **F 7819 1001**

<b>Version</b>	Straight Flute, Form C, 2 - 3 Threads Chamfer						<b>Core Hole Diameter for American Taper Pipe Thread NPT, Taper 1 : 16 acc. to ANSI B 1.20.1</b>				
<b>Type of Hole</b>											
<b>Surface Treatment</b>	Steam Tempered										
<b>Catalogue-No.</b>	2700/78										
<b>Tolerance</b>											
							<p>rough-drill cylindrically</p>  <p>rough-drill cylindrically and grind conically with reamer</p> 				
<b>Application</b>	Unalloyed Steels; Tensile Strength $\leq 800 \text{ N/mm}^2$ add. see Page 16, 17										
<b>Coolant</b>	Cutting Oil or Emulsion										
<b>Cutting Speed v<sub>c</sub></b>	5 - 10 m/min										
							rough-drill cylindrically		rough-drill cylindrically and grind conically with reamer		
<b>d<sub>1</sub></b>	<b>P (Gg1*)</b>	<b>l<sub>1</sub></b>	<b>l<sub>2</sub></b>	<b>d<sub>2</sub></b>	<b>□</b>	<b>X-Dim*</b>	<b>Ø D<sub>1</sub></b>	<b>Depth of Hole</b>	<b>Ø D<sub>1</sub></b>	<b>Ø D<sub>2</sub></b>	<b>Depth of Hole</b>
							mm	mm	mm	mm	mm
1/16	27	56	12	6	4,9	9,7	6,25	12,00	6,00	6,39	12,00
1/8	27	63	12	7	5,5	9,7	8,50	12,00	8,25	8,74	12,00
1/4	18	63	20	11	9	14,2	11,10	17,50	10,70	11,36	17,50
3/8	18	70	22	12	9	14,5	14,70	17,60	14,10	14,80	17,60
1/2	14	80	22	16	12	19,0	18,00	22,90	17,40	18,32	22,90
3/4	14	100	22	20	16	19,5	23,25	23,00	22,60	23,67	23,00
1	11 1/2	110	32	25	20	23,4	29,25	27,40	28,50	29,69	27,40
1 1/4	11 1/2	125	32	32	24	23,9	38,00	28,10	37,00	38,45	28,10
1 1/2	11 1/2	140	36	36	29	23,9	44,25	28,40	43,50	44,52	28,40
2	11 1/2	160	36	45	35	24,3	56,25	28,40	55,00	56,56	28,40
* The recommended X-dimensions are for reference purpose only.											